

Type DBSL Load Cell

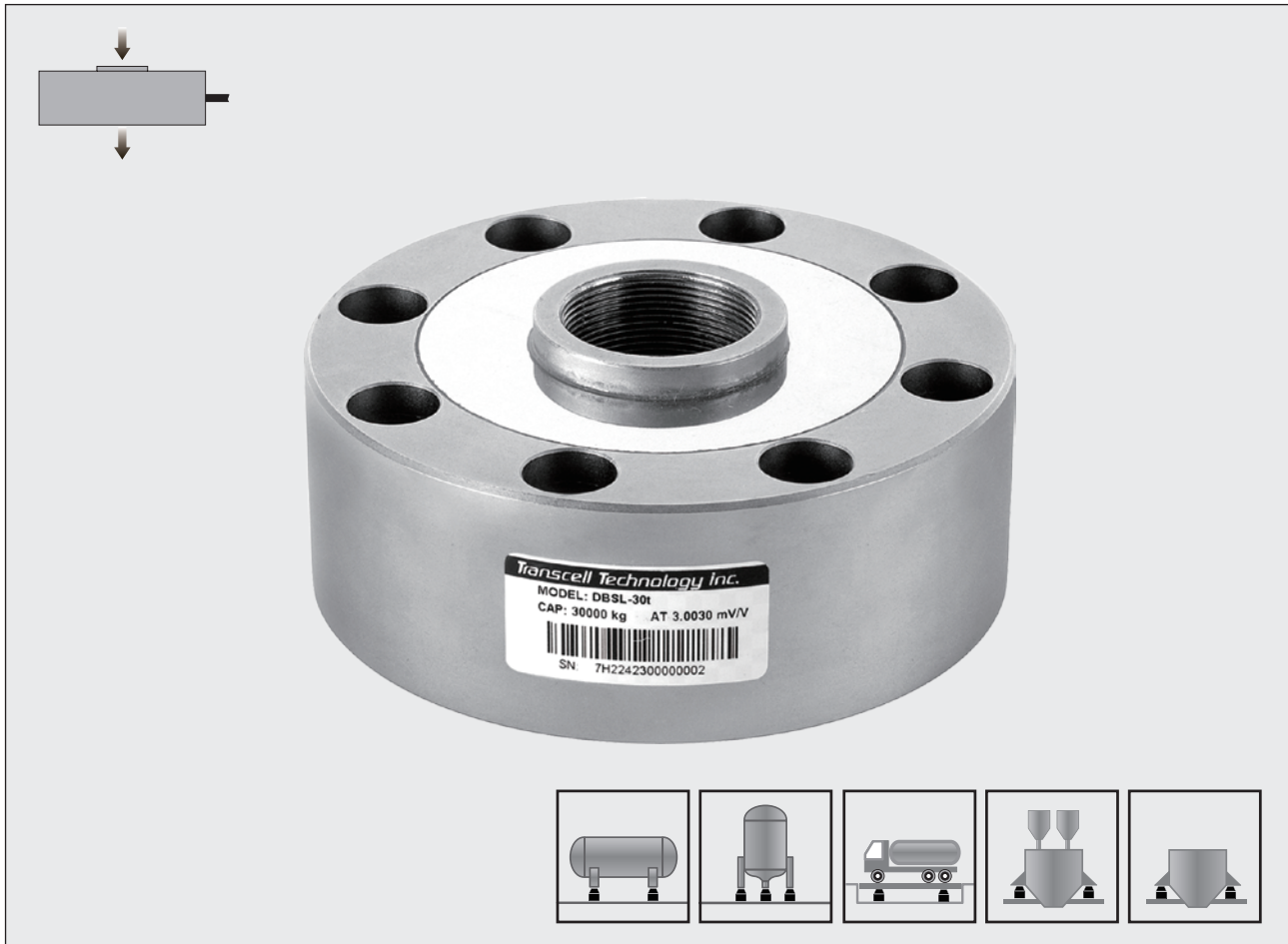

Features 主要特点

- Pancake type load cell
- Alloy steel construction
- High accuracy
- High stability
- Low profile
- Easy to install
- Protected against corrosion by nickel-plated treatment
- Suitable for testing machine, truck scales and big bin & hopper scales, etc.
- 轮辐式传感器
- 优质合金钢材质
- 高精度
- 高稳定性
- 低外形
- 安装简便、快速
- 表层镀镍防腐处理
- 适用于试验机、汽车衡和大型料斗秤等

Schematic 接线方式

- | | | | |
|---------|----------|------|------|
| Red : | + input | 红色 : | + 激励 |
| Black : | - input | 黑色 : | - 激励 |
| Green : | + output | 绿色 : | + 信号 |
| White : | - output | 白色 : | - 信号 |

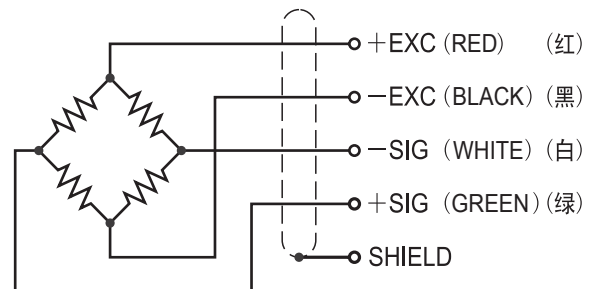

Capacities 量程

1t, 2t, 3t, 5t, 10t, 15t, 20t, 25t, 30t

※ Larger capacities are also provided (可定制更大量程)

Dimensions 尺寸

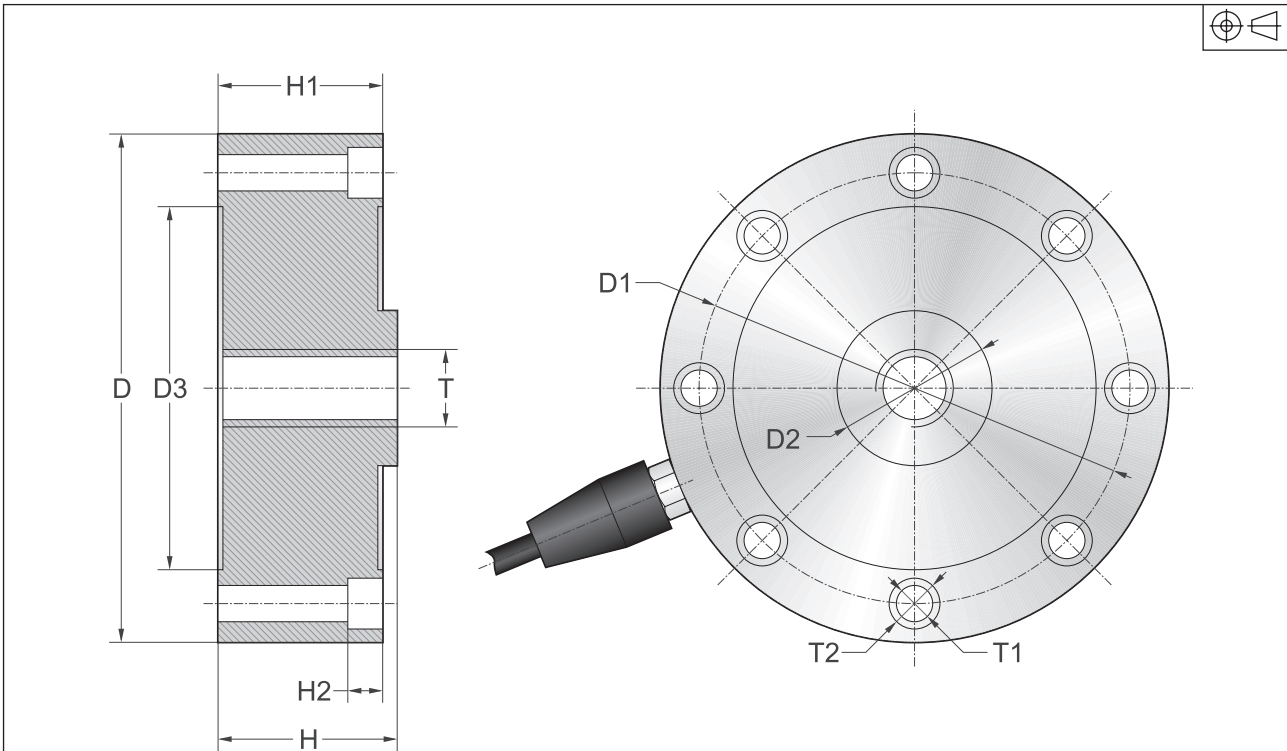

Capacity/量程		D	D1	D2	D3	H	H1	H2	T	T1	T2
1t / 2t / 3t / 5t	mm	Ø105	Ø89	Ø32	75	37	34	7.2	M16×1.5	8×Ø7.5	8×Ø10.5
10t / 15t / 20t / 25t	mm	Ø120.6	Ø101.8	Ø39	83	53.5	41	10.5	M32×1.5	8×Ø8.5	8×Ø14
30t	mm	Ø141	Ø116.8	Ø50.4	96.9	57.2	50.8	11	M40×1.5	8×Ø11	8×Ø18

Specification 技术参数

Rated Output	额定输出	3.0mV/V ±0.25%
Zero Balance	零点平衡	±1% of rated output
Creep after 30 minutes	蠕变	±0.03% of rated output
Nonlinearity	非线性	±0.03% of rated output
Hysteresis	滞后	±0.03% of rated output
Repeatability	重复性	±0.03% of rated output
Temp. effect on output	灵敏度温漂	≤0.002% of applied output/°C
Temp. effect on zero	零点温漂	≤0.002% of rated output/°C
Safe Temp. Range	可用温度范围	-10°C to + 70°C
Temp. Compensated	温度补偿范围	-10°C to + 40°C
Safe Overload	安全载荷	150%
Input Impedance	输入阻抗	775 ohm ± 20 ohm / 387 ohm ± 20 ohm (≤20t)
Output Impedance	输出阻抗	700 ohm ± 5 ohm / 350 ohm ± 5 ohm (≤20t)
Insulation Resistance	绝缘阻抗	≥5000 M ohm (50V DC)
Rated Excitation	推荐激励电压	10V DC/AC
Maximum Excitation	最大激励电压	15V DC/AC
Cable Length	导线长度	6m/10m
Cable Color Code	导线颜色	Red(+ E) Black(- E) Green(+ S) White(- S)

Pancake Type